

smith+noble®

Step by Step Installation Instructions

Metal Blinds



Customer Service 800.248.8888 or visit us online at smithandnoble.com

THANK YOU for choosing smith+noble. Your new Metal Blinds have been custom–crafted to your exact specifications from the highest quality materials. Once in your windows, they will provide you with a lifetime of beauty and trouble-free use.

INSTALLING your new blind is easy. Simply follow our step-by-step instructions. We recommend that you read through all the instructions before you start. If you have questions, our customer service representatives are available at 800.248.8888.

Do not dispose of packaging until the blinds are operating to your satisfaction.

CONTENTS

Getting Started	3
Metal Blinds	4
Attaching the Installation Brackets	5
Attaching Hold Down Brackets	6
Operating Your Blind	6
Troubleshooting	7
Care + Cleaning	8
Safety	8

For assistance, call smith+noble
Customer Service at
800.248.8888
Visit our website at
smithandnoble.com

GETTING STARTED

Remove the blind from the packaging.

Do not dispose of packaging until the blind is operating to your satisfaction.

Check the diagram to make sure you have all the parts indicated for the appropriate type of installation.

NOTE: Do not lower the blind yet.

TOOLS you will need to install your blind: pencil, screwdriver, 1/4" nut driver, level, pliers and a drill with 1/8" drill bit.

Your brackets must be securely attached to the mounting surface. When screwing into a surface, the included screws must hit wood studs. Otherwise, use a secure fastener as illustrated (not included).

WALLBOARD OR PLASTER:

Use a secure fastener designed for hollow wall applications.

METAL: Pre-drill holes and use the included screws.

CONCRETE, STONE, BRICK OR TILE:

Use a masonry drill and appropriate plugs, anchors or screws.

When selecting a fastener, make sure it is designed to support the weight of the product being installed. Follow the fastener manufacturer's instructions for proper installation.

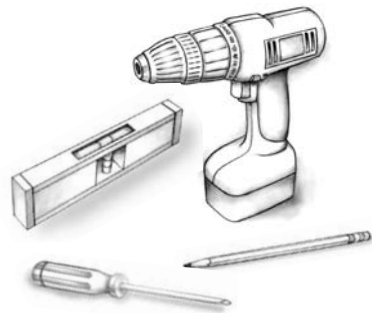

NOTE: When installing screws with a drill, be careful not to over-tighten. This may cause the screw to break off in the wall or window frame.



METAL BLINDS

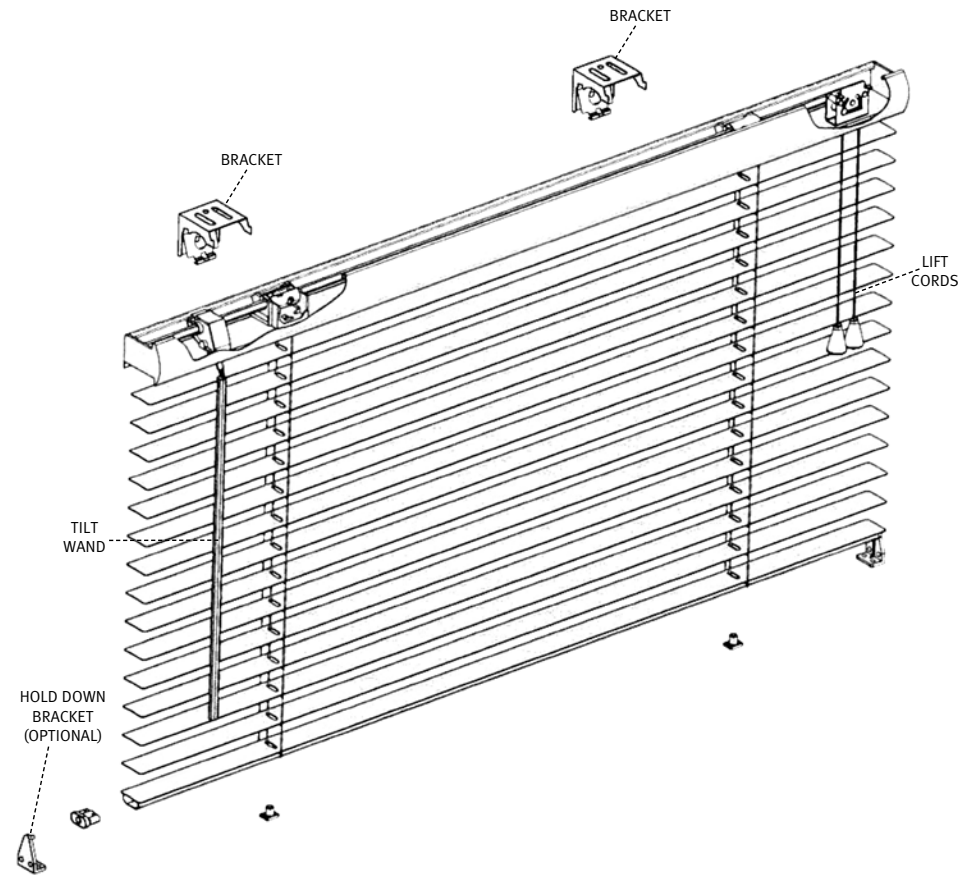

ATTACHING THE BRACKETS

Position the first two installation brackets along the mounting surface and at each end of the headrail.

BRACKET CHART

Blind WIDTH	# OF BRACKETS
Up to 60"	2
60 1/8" to 77 3/4"	3
77 7/8" and up	4

Each bracket should be set 2" from each end of the headrail. When using a third or fourth installation bracket if the width requires, center it between the end brackets. Make sure the brackets will not interfere with the cord mechanism or any other internal parts.

Inside Mount

Center the shade in the window frame. Mark the bracket for mounting hole locations, making sure they are square and equally spaced. Screw brackets into wall or window jamb as required.

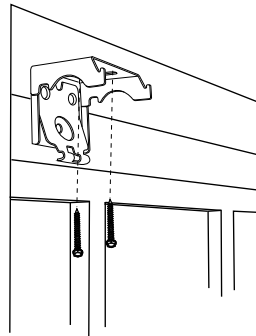

Outside Mount

Center the blind over the window opening at the desired height. Mark the position of the bracket on the wall. Make sure the brackets are level.

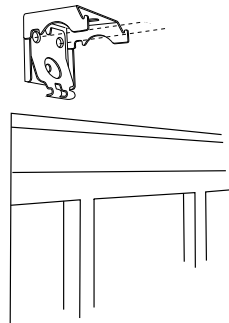

HOLD DOWN BRACKETS (OPTIONAL)

With the hold-down brackets attached to the bottom rail, lower the blind to the hold down bracket mounting surface and mark the bracket locations. Attach the hold down brackets at the bottom of the window or door with the included screws as shown. To attach the bottom rail, gently pull the brackets out slightly, and insert the pins into the holes on the bottom rail of the blinds.

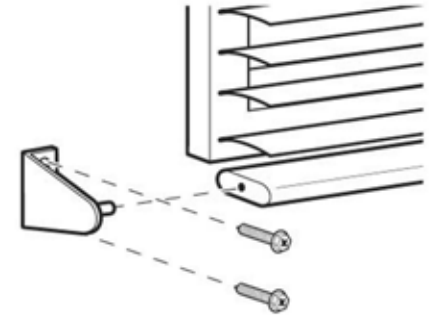

OPERATING YOUR BLIND

To lower the blind, pull the cord down and towards the center of the shade to unlock the cord. Then, slowly release the cord until the shade reaches the desired location. Move the cord past the outer edge of the shade and let go to lock the cord.

To raise the blind, pull the cord straight down until the shade reaches the desired location. Move the cord past the outer edge of the shade and let go to lock the cord.

My Blind Doesn't Lift:

Check to make sure cord is not caught in headrail. If hold down clips were used, make sure they have been released.

My Blind Will Raise And Lower But Will Not Tilt:

Check inside the headrail for obstructions. Make sure all of the slats are laying properly on the ladders.

My Blinds Raise Unevenly:

Raise blind to the "up" position, open the tassel, untie the knots on the cords, even out the cords, then re-tie the knots and re-assemble the tassel.

My Slats Are Hanging Out Of Alignment:

Lower the blind completely. While firmly holding the bottom rail, gently tug on the lift cords until the slats are even.

One Side Of The Blind

Does Not Raise:

Make sure the lift cords are still fastened to the bottom rail. If they are not, please call Customer Service for assistance.

or

Look inside the headrail to make sure that cords are not caught on or under something.

- Clean soiled mini-blind surfaces with a mild soap solution. Do not steam, hot water, bleach or any abrasive or solvent-based cleaners. Do not machine wash.
- To ensure proper drying, provide adequate ventilation for blinds, remove bottom rail plastic end caps, and tip headrail and bottom rail to drain water.

SAFETY

All Smith+Noble blinds are made with tassel systems designed to protect small children and pets if they become tangled in the cords. When the blind is raised, excess cords may hang within the reach of children or pets. In these situations, use a cord cleat as shown at right to prevent possible injury. To obtain a cord cleat call Smith+Noble Customer Service at 800.780.8889.

