

# SMITH & NOBLE

---

STEP BY STEP INSTALLATION INSTRUCTIONS

## *Natural Woven Shades*

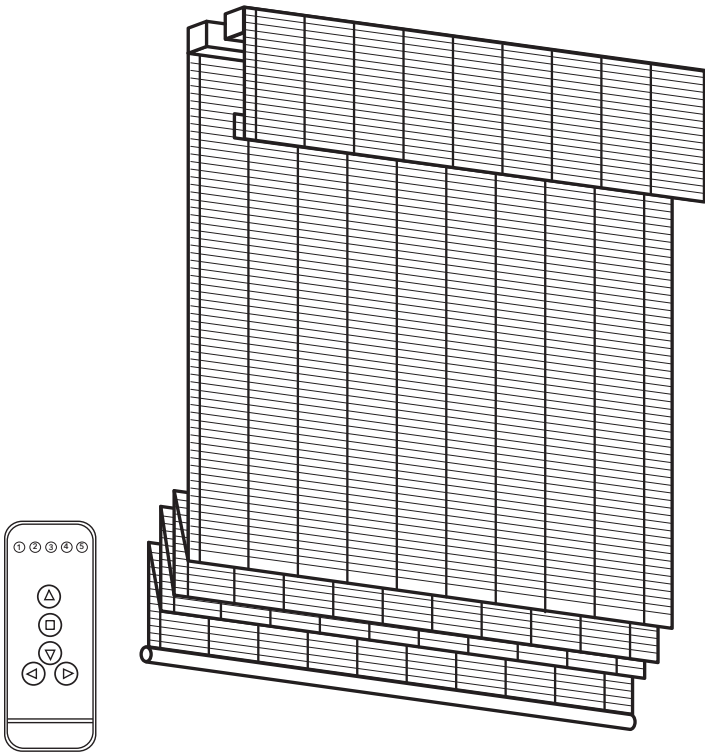

Motivia™  
Motorization

---

---

# Everything You Need

## A Smooth Set-Up

We want you to love your new window coverings and that includes having a smooth installation experience. If you encounter any difficulties or questions, please reach out to us for help. It's why we're here. Call us at 800.248.8888 or visit [www.smithandnoble.com/knowhow](http://www.smithandnoble.com/knowhow) for more info on installation.

We recommend you hold on to all packaging until your window coverings are fully installed. Should something go wrong (we strongly doubt it), we want any potential returns to be a painless as possible.

---

### Customer Service Hours

Monday – Friday: 6am – 7pm PT

Saturday – Sunday: 7am – 4pm PT

[smithandnoble.com](http://smithandnoble.com)



---

## Table of Contents

<i>Step 1 -</i>	Getting Started .....	3
<i>Overview -</i>	Motorization .....	4
<i>Step 2 -</i>	Mounting the Brackets .....	5 - 6
<i>Step 3 -</i>	Attaching the Power Source .....	7
	Attaching the Battery Pack .....	7
<i>Step 4 -</i>	Operating the Remote Control .....	8
	Troubleshooting .....	9
	Safety .....	10
	Care & Cleaning .....	10
	Warranty .....	Back Cover

Getting Started

First, make sure you have all the parts and tools required to install your shades.

ALL THE HARDWARE YOU'LL NEED:

Pencil, screwdriver, 1/4" nut driver, level, and a drill with a 3/64" drill bit.

Then find wooden studs where you'll want to attach the brackets; if you need to mount your shades to wallboard or plaster, use a secure fastener designed for hollow wall applications. For metal surfaces, pre-drill holes and use the included screws. For concrete, stone, brick, or tile surfaces, use a masonry drill and appropriate plugs, anchors, or screws.

It's important when selecting a fastener to make sure it's designed to support the weight of the shade. Follow the fastener manufacturer's instruction from there on out.

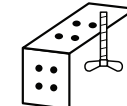
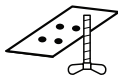
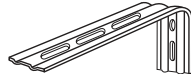
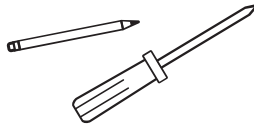
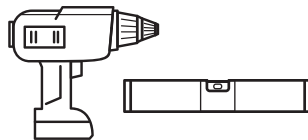
 <p>SCREWS</p>	 <p>OUTSIDE MOUNTING BRACKETS</p>
 <p>INSIDE MOUNTING BRACKETS</p>	 <p>EXTENSION BRACKET (OPTIONAL)</p>
 <p>PENCIL &amp; SCREWDRIVER (NOT INCLUDED)</p>	 <p>POWER DRILL &amp; LEVEL (NOT INCLUDED)</p>

Motorization

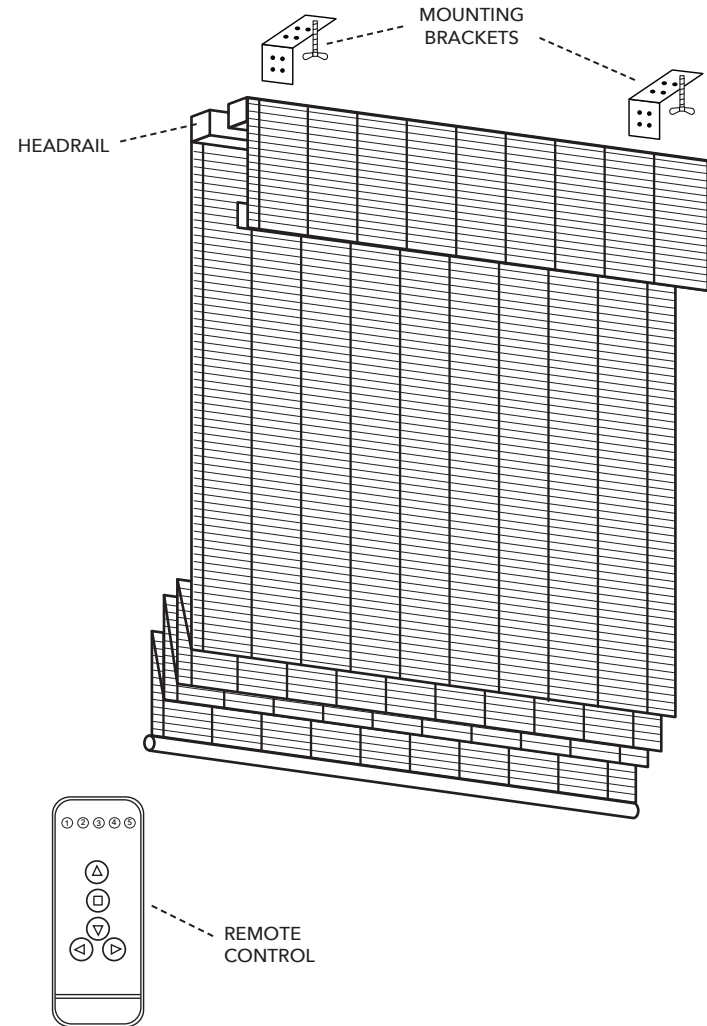

## Step 2 – Mounting the Brackets

### Inside Mount

For an inside mount, hold the shade inside the window frame. Center the shade so the space between the end of the headrail and edges of the window frame are equal.

The brackets are mounted with two screws flat against the top sill surface. To fully recess the shade requires a flat surface with a minimum depth of 2". A minimum depth of ¾" is required.

With the brackets installed and level with one another, remove the wing nuts from the bolts and place the shade onto the brackets. With the bolts coming through the mounting slots on each of the headrail, reinstall the wing nuts onto the bolts and hand tighten.

**NOTE:** Inside mount Waterfall Shades will have a short flap in the back of the shade to hide the mechanisms.

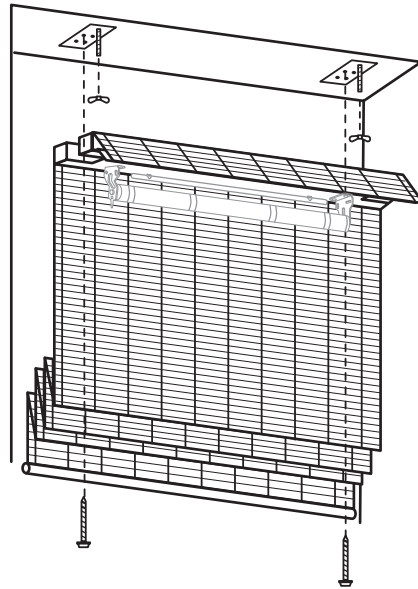

BRACKET QTY	SHADE WIDTH
2	up to 36"
3	36 1/8–72"
4	72 1/8–96"
5	96 1/8–120"

## Step 2 – Mounting the Brackets

### Outside Mount

Center the shade over the window opening at the desired height. Mark the position of the ends of the headrail on the wall with a pencil.

Measure ½" in from the marks on each side and mark with a pencil. Place the outside edge of each bracket on these marks and attach with the screws provided using 2 screws per bracket.

With the brackets installed and level with one another, remove the wing nuts from the bolts and place the shade onto the brackets. With the bolts coming through the mounting slots on each end of the headrail, reinstall the wing nuts onto the bolts and hand tighten.

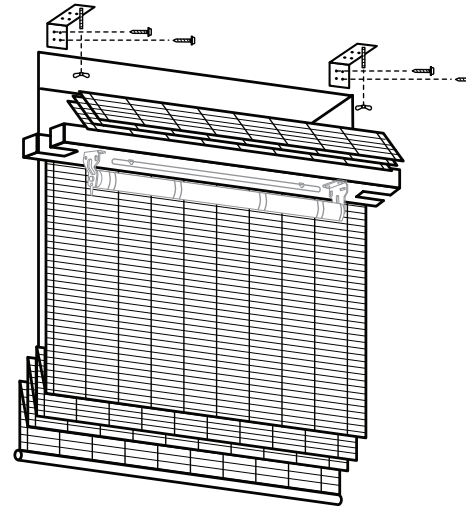

## Step 3 – Attaching the Power Source & Batter Pack

### Attaching the Power Source

When attaching the Power Source to the shade, first plug the battery pack wire into the motor wire.

Battery comes mounted to headrail in front of take up tube.

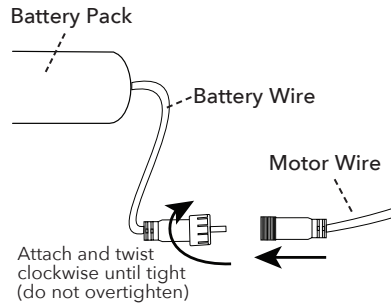

### Attaching the Transformer (optional)

Plug the transformer wire into the motor wire. Secure the wire behind the shade and along the window casing as required.

Plug the transformer into an electrical outlet.

If the wire is not long enough to reach, optional 48" extension wires are available.

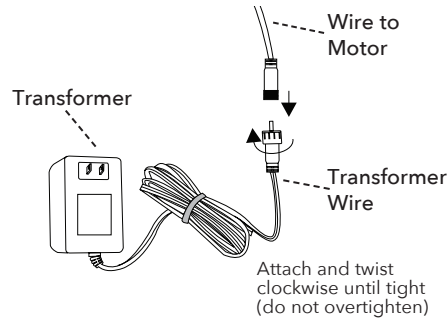

### Mounting Battery Pack on Headrail

If needed, insert included batteries into the battery pack following the diagram on the outside of the battery pack.

Attach the pack clips to the headrail as pictured.

Then press the battery pack into clips.

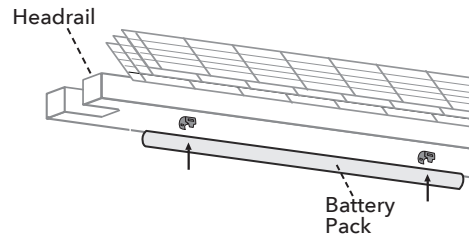

### Mounting Battery Pack on Wall

Attach the pack clips with the screws provided. If necessary, remove shade to mount the clips in the desired location.

Then press the battery pack into clips.

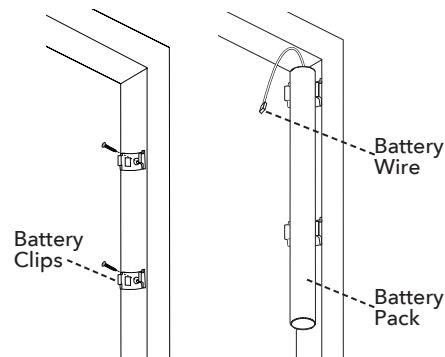

## Step 4 – Operating the Remote Control

### Remote Control

For added protection, your remote control arrived with a protective film on the top. Please remove this film prior to use.

Select the desired channel with the CHANNEL key. The channel indicator light will illuminate the channel that is on. If all 5 lights are lit, the remote will control all 5 channels at once.

Tapping the UP or DOWN keys for less than 2 seconds will move the shade in short steps. Holding the UP or DOWN keys down for more than 2 seconds before releasing, will operate the shade in the faster standard speed.

Press the UP or DOWN keys to raise or lower the shade. Vanes will open when shade is completely lowered.

Press the STOP key to stop the shade anywhere along the window.

### Setting and Using a Favorite Position:

Use the UP or DOWN buttons to position the shade at the desired "favorite" position. First press and hold the LIMIT button on the back of the remote with a small screwdriver or tip of a pen. While holding the LIMIT button press and hold the UP button. Release both buttons when the shade jogs.

With the shade at either the upper or lower limit, simply press the STOP button to bring the shade to the "favorite" position. To go to the "favorite" position from any other location, make sure the shade has been stopped for at least three seconds before pressing the STOP button.

Refer to the Motorization Guide for additional details.

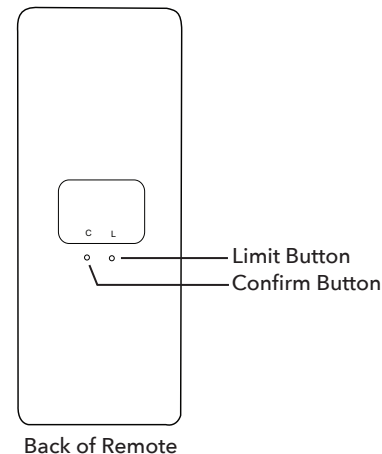
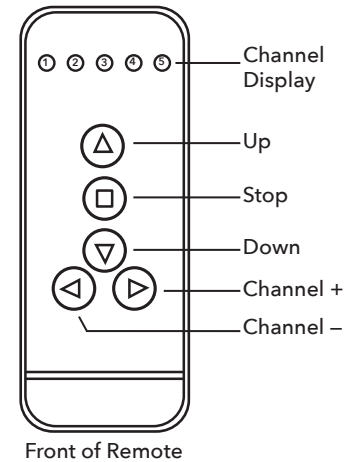

PROBLEM	SOLUTION
The shade does not move	<ol style="list-style-type: none"><li>1. Check that the power source and motor are connected properly.</li><li>2. Confirm the batteries in battery pack are fresh.</li></ol>
The shade only goes in one direction (up or down)	The limit setting was unsuccessful and needs to be reset. Refer to Motorization Guide.
The indicator light on the remote does not light up or the remote-controlling range becomes shorter.	Replace the battery in the remote (CR2430 Lithium)
The shade stops working or works intermittently	Replace the batteries in the pack with 8 fresh AA alkaline batteries.
Shade goes up when the down button is pushed, and goes down when the up button is pushed.	Press the "Limit" button on the underside of the remote and the "Stop" button at the same time. Hold until the shade jogs once. The shade should now move in the correct direction.
The motor beeps when operated	The battery power is low. Replace the batteries in the wand with 8 fresh AA alkaline batteries

*If these suggestions don't work, then please give us a call or visit our website.*

### Care & Cleaning

Occasional light vacuuming with a soft bristle attachment or gentle feather dusting is all that is required to keep your shades looking fresh and neat.

---

### Safety First. Style Second To None™.

Great style should never come at the cost of safety. Every Smith & Noble window treatment conforms strictly to today's safety standards, including permanent tie-down devices and built-in cord stops. To protect young children and pets, there's no better way to eliminate risk than to use one of our Motivia motorized products.



---

## Warranty Service

The enjoyment of your window covering should be everlasting, which is why our products come with a limited lifetime warranty. The warranty applies to the original owner, requires a proof of purchase (hang on to your receipt!) and covers defects in material or craftsmanship. Hardware must have been properly installed. We reserve the right to determine if your hardware warrants a repair or a replacement. Visit [smithandnoble.com/guarantee](http://smithandnoble.com/guarantee) to see full details. In need of warranty service? Call us at **800.248.8888** and we'll arrange for a repair or replacement ASAP.

---